

Antenna Deployment Technical Brief

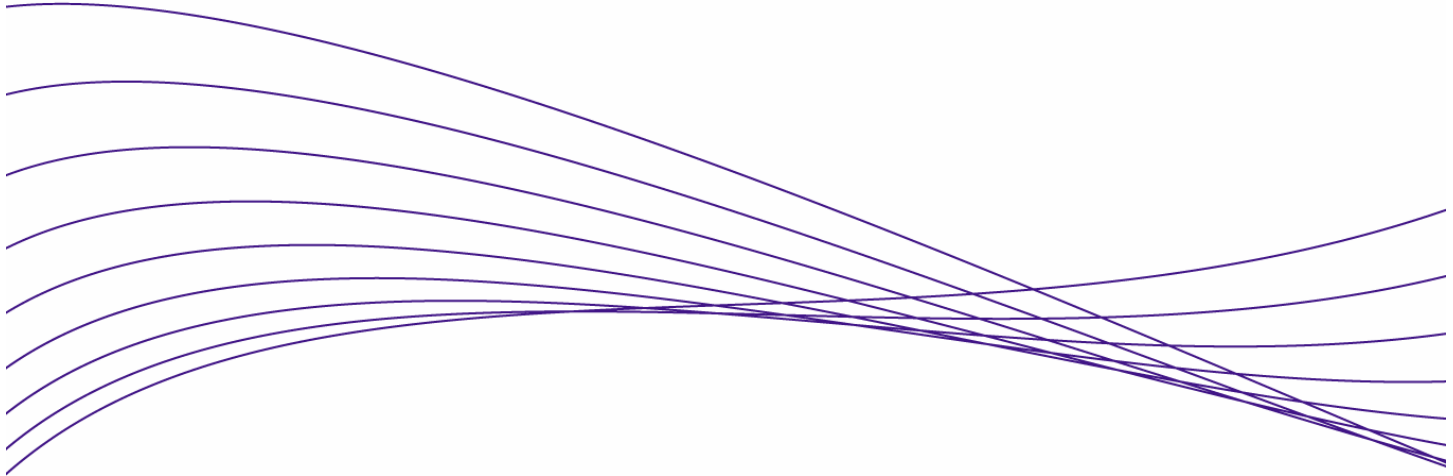

Introduction	2
Antenna types	2
Omni directional antennas	2
Directional antennas	2
Diversity antennas	3
High gain directional antennas	3
Wide angle sector directional antennas	4
Antenna properties	5
Antenna Gain	5
Polarization	5
Beamwidth	7
Bandwidth	7
Voltage Standing-Wave Ratio (VSWR)	7
Path loss	7
RF Link Budget	8
Site Survey Tips	9
Antenna Installation Recommendations	9
Calculating EIRP	12

Introduction

This paper is intended to give guidance in how to, select, install, and configure access points and antennas. Additionally, it will provide information on how to do a wireless LAN site survey. The various cable and antenna connector types that ProCurve Wireless Access Points use will be shown, as well as examples of how to estimate the losses and actual range of a given wireless installation.

Antenna types

Omni directional antennas

Omni directional antennas have a radiation pattern that is donut shaped with the antenna at the center of the donut. This means that with the antenna oriented vertically, the signal coverage is equal in all directions in the horizontal plane. Omni directional antennas should be mounted in the center of the coverage area above most obstacles.

Figure 1: Radiation pattern of an omni directional antenna such as a dipole antenna:

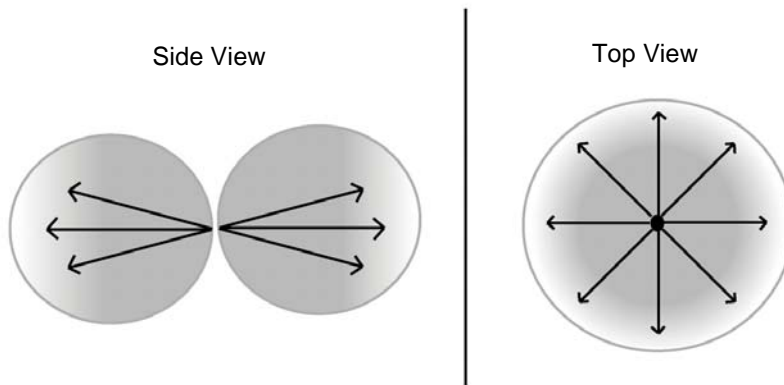

Directional antennas

Directional antennas have a radiation pattern that is more focused than omni directional antennas. The coverage area is limited to a conical area of various widths depending on the type of directional antenna.

A patch antenna is a type of directional antenna and may have a radiation pattern that is 30 to 90 degrees wide. Patch antennas usually have a flat planar construction and may be square or rectangular in shape. They are usually constructed using microstrip technology.

Figure 2: Three dimensional plot of a typical radiation patter of a typical directional antenna

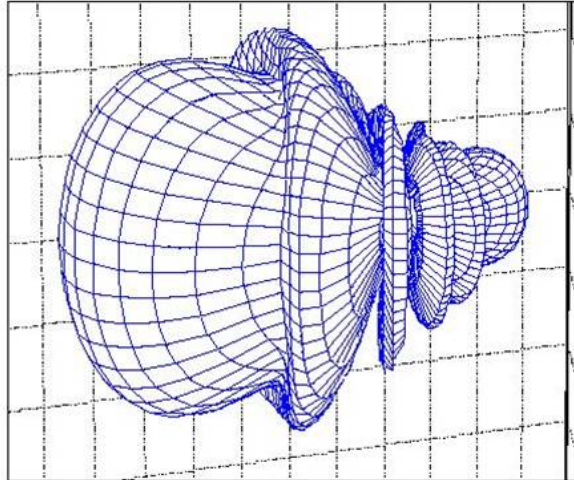

Diversity antennas

Diversity antennas provide two antennas in one unit. They have two connections to an access point. Both connections go to the same radio on the wireless access point.

The access point must support diversity mode which means the access point alternates to receiving signals on one or the other antenna, depending on which is generating the strongest signal. This improves the access point's performance when there is multipath interference of signals. Multipath interference occurs when signals reflected off different surfaces arrive at the receiver at slightly different times and strengths. Diversity antennas may be omni directional or directional.

Figure 3: Diversity antenna- note the two cables used to connect to the access point.

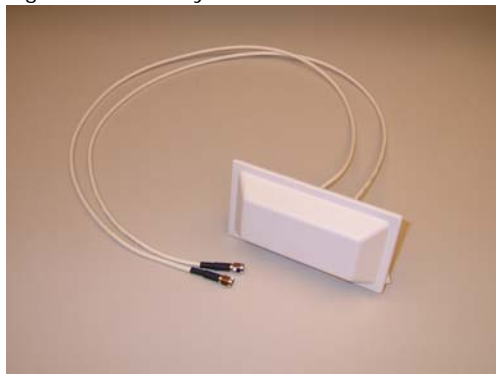

High gain directional antennas

A point to point high gain antenna is a directional antenna that has a focused radiation pattern. The radiation pattern is typically a cone 10 to 30 degrees wide. A yagi and a parabolic dish are examples of high gain directional antennas.

Figure 4: Radiation pattern of a high gain yagi antenna (directional).

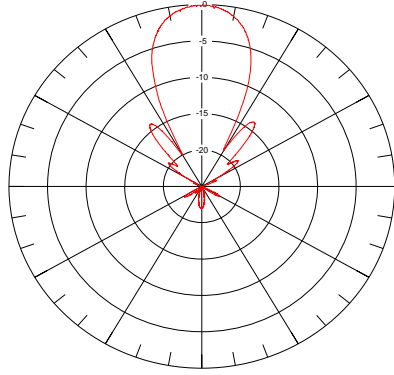

Wide angle sector directional antennas

Wide angle sector antennas are another type of directional antenna that has a radiation pattern that is 60 to 120 degrees wide in the Horizontal plane. These are used in environments where a wide area needs to be covered from a single location. A typical application would be to install three of them on one mast, thus giving 360 degree coverage. Each sector would be attached to a different radio which allows them to be on different channels in order to minimize interference between different sectors.

Figure 5: Wide angle directional antenna radiation pattern

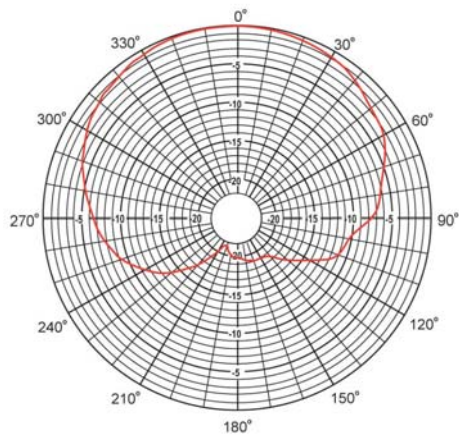

Antenna properties

Antenna Gain

Antenna gain is a measure of how strong a signal is received or transmitted compared to either an isotropic (point source) antenna or to a dipole antenna. An ideal isotropic (point source) antenna radiates energy outward in a perfect sphere.

Figure 6: Three dimensional diagram of the radiation pattern of an isotropic radiator

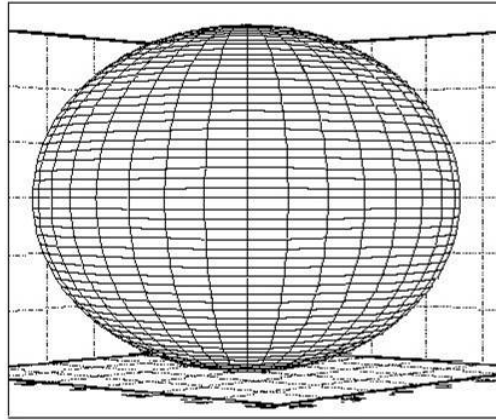

Antennas have no active components, thus they do not amplify RF energy or increase the overall signal level of a radio device. Instead, antennas “direct” or “focus” the radiated RF energy into a specific pattern. In other words, antennas provide gain by focusing the radiated energy into a space smaller than the spherical volume that would be covered by an isotropic point source. For example, coverage for a dipole antenna (with gain typically around 2.0 dBi) looks like the omni directional radiation pattern shown in Figure 1.

Antenna gain is expressed in either dBi (relative to an isotropic radiator) or dBd (relative to a dipole antenna):

$$\text{Gain (dBi)} = \text{Log}_{10} (\text{antenna signal}/\text{isotropic signal})$$

$$\text{Gain (dBd)} = \text{Log}_{10} (\text{antenna signal}/\text{dipole signal})$$

Polarization

The polarization of an antenna is the orientation that the electric field of the wireless signal component is radiating in. Antenna radiation patterns are described by radiation pattern plots in typically two planes: The Electrical (also called Elevated) or E plane and the Magnetic (also called Azimuthal) or H plane. These plots depict the gain on a circular grid with the maximum gain at 0 degrees. The rest of the plot shows the gain from the other angles relative to the maximum (see figure 5). The Elevated plane is the vertical plane which is parallel with the antenna radiating element. The H plane is the plane that is perpendicular to the radiating element.

When using a pair of antennas for a point to point link, to get maximum signal transfer, make sure they are mounted with the same polarization. In other words, if a pair of the same type of antennas is being used, make sure they are both mounted with the same orientation. If one antenna is mounted vertically then the receiving antenna should also be mounted vertically.

Figure 7: Antenna polarity examples

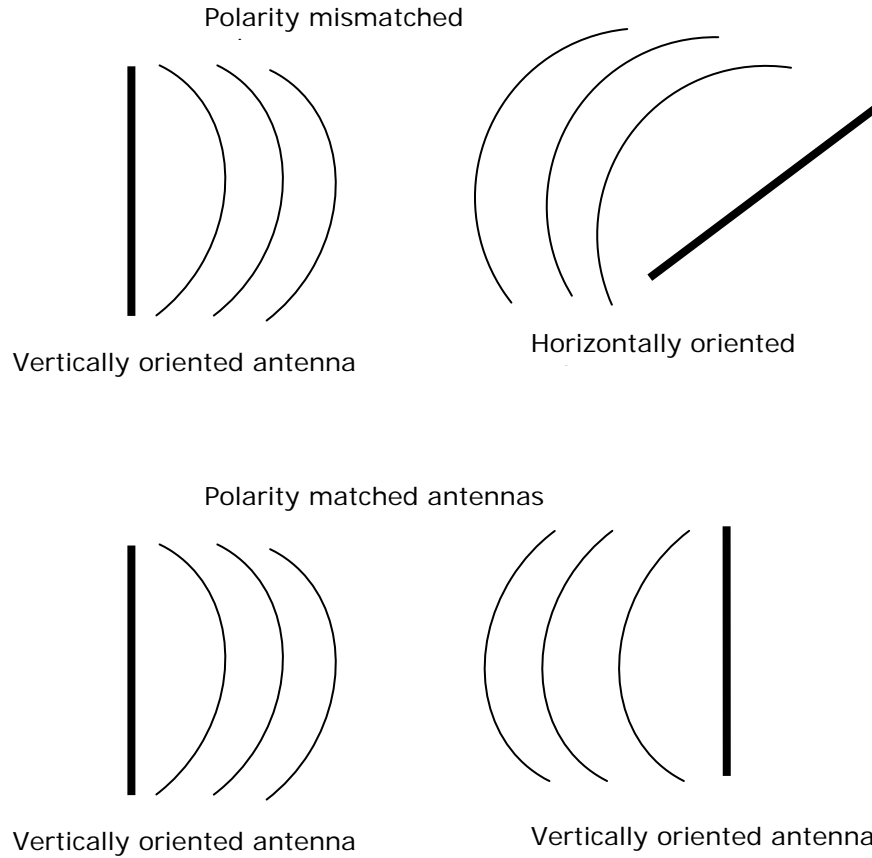

If you are unsure about the polarization, then rotate one antenna along the axis between the two antennas until you achieve the highest signal strength. That should put the two antennas in the same polarization.

Figure 8: Diagram of vertically polarized and horizontally polarized wireless radio signals

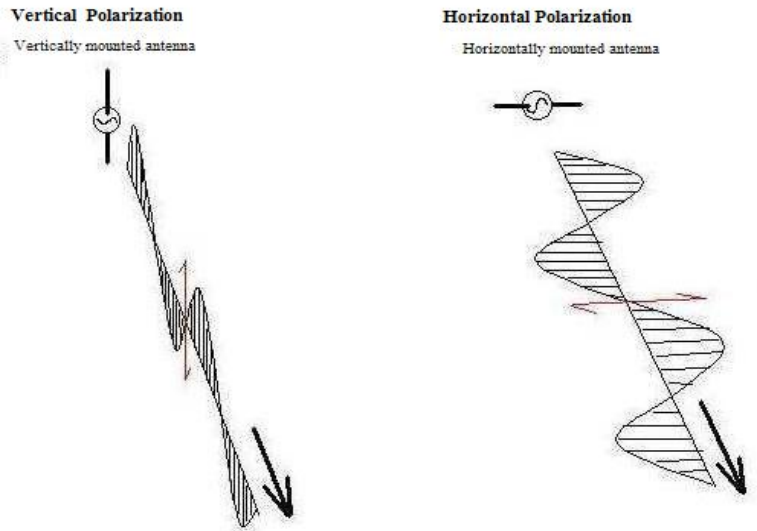

Beamwidth

Antenna beamwidth is the angle between the points on the main lobe at which the power drops off to half of its peak power. As the gain of the antenna increases, the beamwidth decreases due to the antenna's ability to focus radio waves into a narrow beam.

Bandwidth

The bandwidth of an antenna indicates the frequency or frequency range in which it is designed to be used. For example an antenna designed for use in 802.11b networks would have a bandwidth of 2.4 GHz. There are also dual band antennas designed for use in two different frequency bandwidths such as 2.4 GHz and 5 GHz.

Voltage Standing-Wave Ratio (VSWR)

VSWR is a measure of how well matched an antenna is to the cable impedance. A perfectly matched antenna would have a VSWR of 1:1. This indicates how much power is reflected back or transferred into a cable. For example if a cable with a 50 ohm impedance is used to connect to an antenna that has an impedance of 100 ohms then the VSWR would be 2:1 which translates to about 0.5 dB transmission loss. An antenna with 50 ohm impedance should be used with 50 ohm cable.

Path loss

As a signal propagates through the air it experiences some loss. This is called path loss. This is due to both to the signal spreading out over a wider and wider area and to some signal being absorbed by the air itself as the signal travels farther and farther away from the source antenna. For 802.11b, Table 1 provides estimates for path loss over various distances.

Note:

A 6 dB increase in gain equates to a doubling of the propagation distance.

Table 1: Path loss (dB)

meters	Path loss (dB)	
	miles	2.450 GHz
6	0.0034	55
12	0.0068	61
25	0.0142	68
50	0.0284	74
100	0.0568	80
200	0.1136	86
400	0.2273	92
800	0.4545	98
1600	0.9091	104
17600	10.0000	124

RF Link Budget

A link budget calculation determines how much of the transmitter's output power is available at a particular receiver location after the transmitter output power, antenna gain, all cable and path losses are accounted for. These calculations should take into account:

- Radio transmit output power
- Transmitter cable and connector losses
- Transmitter antenna gain
- Path loss
- Receiver antenna gain
- Receiver cable and connector losses
- Margin needed above noise floor (typically 10-15 dB).

For example, lets say we have an AP that has a transmit power of +15dBm with a 10 dBi antenna gain. The transmit antenna is connected to the access point with a 5 foot long extension cable of LMR 195 cable which causes a cable loss of approximately one dB. The signal leaving the antenna is approximately $15 + 10 - 1 = 24\text{dBm}$. We need to determine if this signal is usable 300 feet away. The path loss for 100m (300ft) transmission through open air is 80dB. So at the receiving antenna the signal would be $+24 - 80\text{dBm} = -56\text{dBm}$. A usable signal must typically be 10-15dB above the local noise floor. If the noise floor in the example is -70dBm then the -56dB received signal is 15dB above the noise floor and so would be adequate for reception.

Figure 9: Diagram of a wireless radio signal and noise floor as it would appear on a spectrum analyzer.

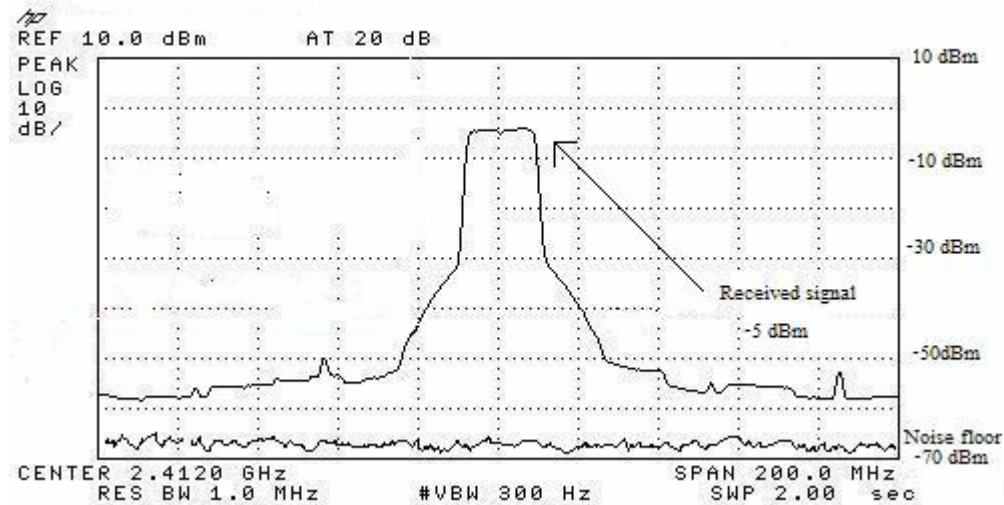

Site Survey Tips

To do a site survey, install an access point in the area to be surveyed. Next, using an application, like Netstumbler, record signal strength. A spectrum analyzer may also be used to record the signal strength as you move about and verify that the areas of intended coverage have signal strength of at least 10-15 dB above the noise floor. Measuring the throughput of 1500 byte (large) packets is an important indicator of good performance as well since as signal strength is reduced, data throughput is also reduced. Moving around and noting the throughput with large (1500 byte) packets is a good technique for doing a site survey as well.

Signal to Noise Ratio (SNR) is a measure of how strong a received signal is relative to the noise level. A SNR of 25 or better is important for good performance. Some wireless pc card client managers will display this value. This can be used to estimate how good the coverage is in an area using a laptop with a wireless client card. Some wireless client cards will just display signal level. Signal level is also useful if you already have an idea of the noise level in the area.

Look for sources of interference from wireless telephones or other 802.11 networks in the frequency range of 2.4 GHz for 802.11b/g, or 5 GHz for 802.11a. Investigate ways of reducing the interference from these sources. Talk with your neighbors. Use sector or directional antennas to focus your coverage area and thus reduce the interference being received as well as reducing the interference that you may cause for your neighbor. Also select channels that are different than the source that is creating interference. For example if your neighbor is using channels 1 and 11, then try using channels 2 and 6.

After documenting the coverage, formulate a plan to provide coverage using a combination of omni directional, patch and diversity antennas.

Also see the [Wireless LANS: Planning the Site Assessment Technical Brief](#) for more information on doing a wireless site assessment.

Antenna Installation Recommendations

It is important to install the antenna at an appropriate height. If it is installed too high, most of the signal will be above the intended receivers or clients. If the antenna is installed at a height that is too low, then nearby obstacles will reduce and reflect too much of the signal and create large shadow areas where the coverage is weak.

Planning the wireless coverage is a lot like planning sprinkler coverage for watering a lawn. Use omni directional antennas to cover large circular areas and directional and sector antennas to cover conical or triangular areas. Draw out the floor plan and draw in the areas intended to be covered by each access point and antenna. Then test this coverage using the surveying techniques discussed above.

Add antennas and access points to areas of weak coverage until the desired level of service is achieved.

Outdoor installations have the added concern of lightning. Antennas installed outdoors must be installed with lightning protection in mind. Check your local building codes and follow those requirements. Also make sure a lightning arrestor is installed between the outdoor antenna and the access point in order to help protect it from damage. If any outdoor antenna cables are run into a building, use a lightning arrestor right at the entrance to the building to prevent damage to the access point inside the building.

It is also good practice to waterproof any outdoor cable connections since moisture inside these connections will cause corrosion and increase the attenuation of the connection. This will result in signal loss and a reduction in system gain.

If the antenna will be mounted more than 1 meter away from the access point, then an extension cable may be required. The cable that is attached to the antenna is called a pigtail. Sometimes an adapter cable with two different types of connectors is needed in order to connect an antenna to an access point with a different connector type.

Most ProCurve antennas have reverse polarity SMA (SubMiniature A) male connectors. The ProCurve yagi antenna (J8448A) has an N-type male connector. N-type female to MC card and N-type female to RP-SMA adapter cables are included with this antenna.

Figure 10: N-type to MC card adapter cable that is included with the J8448A ProCurve yagi antenna



The ProCurve Wireless Access Point 530 and the ProCurve Wireless Access Point 420 has Reverse-polarity SMA male connectors. The ProCurve Wireless Access Point 520wl radio cards have MC card connectors. Most of the ProCurve antennas will connect directly to the ProCurve Access Points 420 and 530, but require an adapter cable (J8447A) to connect to the ProCurve Access Point 520wl.

Figure 11: Reverse Polarity-SMA Male connector



Figure 12: Reverse Polarity-SMA female connector



Figure 13: N-type Male connector



Figure 14: N-type Female connector



Figure 15: J8447A MC card to Reverse Polarity-SMA adapter cable



Figure 16: Right Angle MC card connector



If an extension cable is required, then the installer will need to take the added insertion loss into account when planning the installation. Cable types commonly used for antenna extension cables are LMR 195 and LMR 400. LMR 195 has 50 ohms of impedance at 2.4 GHz and a loss of 0.19 dB/ft. LMR 400 has 50 ohms of impedance at 2.4 GHz and a loss of 0.064dB/ft.

Table 2: Loss vs. Cable Length for LMR 195 and LMR 400

Length feet	Cable type	Loss per foot dB	Loss at 2.4 GHz dB
5	LMR400	0.064	0.32
10	LMR400	0.064	0.64
15	LMR400	0.064	0.96
20	LMR400	0.064	1.28
25	LMR400	0.064	1.6
50	LMR400	0.064	3.2
2	LMR195	0.19	0.38
5	LMR195	0.19	0.95
10	LMR195	0.19	1.9
15	LMR195	0.19	2.85
20	LMR195	0.19	3.8

The lower loss cables are thicker and require bigger connectors such as an N-type. LMR 195 extension cable can be obtained with Reverse polarity SMA connectors whereas LMR 400 requires N-type connectors. As illustrated in Table 2, if a long extension cable is needed, then a cable type like LMR 400 should be used to keep the cable losses to a minimum.

Calculating EIRP

EIRP stands for Equivalent Isotropically Radiated Power. EIRP is the total effective power radiated by an antenna. This includes the transmit power of the radio minus any losses from the cables and connectors plus the gain of the antenna. All units are expressed in decibels (dB), which is a logarithmic relational measure of a change in power (watts or milliwatts). Power gain and loss are measured in dB. Power can be expressed in milliwatts or dBm

$$\text{EIRP} = \text{Transmit Power}_{\text{radio}} - \text{Loss}_{\text{cable}} + \text{Gain}_{\text{antenna}}$$

A good rule of thumb to remember here is that a change of -3dB is equal to a 50 percent power drop. And conversely an increase in power of 3dB is equivalent to doubling the power level. This can be seen in Table 3.

$$\text{Power (dBm)} = 10 * \log (\text{power(mW)}/1\text{mW})$$

Table 3: Power values in mW and dBm

mW	Watts	dBm
0.01	0.00001	-20.0
0.1	0.0001	-10.0
1	0.001	0.0
2	0.002	3.0
3	0.003	4.8
4	0.004	6.0
5	0.005	7.0
6	0.006	7.8
7	0.007	8.5
8	0.008	9.0
9	0.009	9.5
10	0.01	10.0
100	0.1	20.0
200	0.2	23.0
300	0.3	24.8
400	0.4	26.0
500	0.5	27.0
600	0.6	27.8
700	0.7	28.5
800	0.8	29.0
900	0.9	29.5
1000	1	30.0

Here is an example of calculating EIRP:

We have a 5dB gain antenna (including the pigtail) connected to a wireless access point that has a transmit power of 15dBm. The antenna is connected to the access point with an adapter cable that has a loss of 0.7dB at 2.4GHz and a 10 foot LMR 195 extension cable.

Figure 17: Calculating EIRP Example

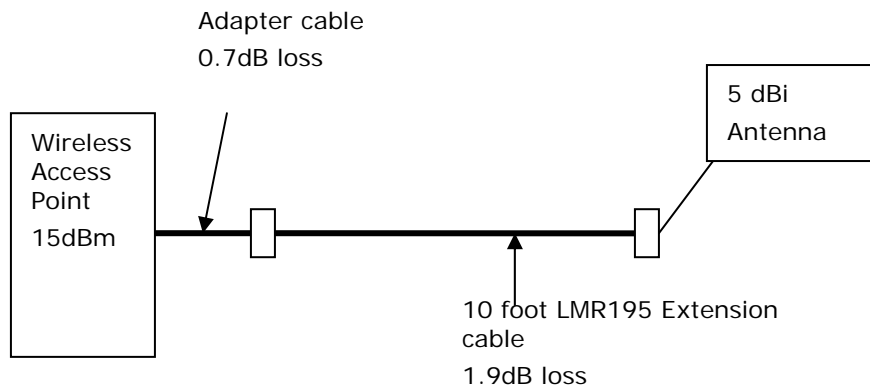

EIRP for this system would be 15dBm radio -0.7dB adapter cable-1.9 dB extension cable +5 dB antenna gain = 17.4dB

To find out more about
ProCurve Networking
products and solutions,
visit our web site at

www.procurve.com



© 2006 Hewlett-Packard Development Company, L.P. The information contained herein is subject to change without notice. The only warranties for HP products and services are set forth in the express warranty statements accompanying such products and services. Nothing herein should be construed as constituting an additional warranty. HP shall not be liable for technical or editorial errors or omissions contained herein.

4AA0-5373ENW, 3/2006